

WIND SENSORS

WITH OBSTRUCTION LIGHT



AN-60-HF

WIND SENSOR WITH OBSTRUCTION LIGHT

Wind Sensor with integrated Obstruction Light

The new Wind Sensor with integrated Obstruction Light guarantees reliable measured values and shadow-free light intensity. The device complies with the lighting requirements according to AVV and the standards and recommendations of ICAO and has a redundant lighting concept.

This combination has many more advantages:

- Optimal measurement results due to missing wind shading
- No maintenance costs and reduced assembly times
- Accurate positioning ensures reduced light pollution
- Corrections of the vertical position with the pendulum

OPTIONAL

- REED-Contact
- Proof varnishing
- Certificate for calibration
- Shaft heating
- Cup star
- rigid
- robust
- resilient

TECHNICAL DATA WIND SENSOR

Housing material	aluminum, grey lacquered	Connection	plug or cable
Housing	Ø 60 mm	Weight	ca. 1,7 kg
Housing length	386 mm	Maximum load (Current output)	600 Ω
IP code of housing	IP65	Accuracy	± 3 % + 0,5 m/s Offset
Measuring range	0–40 m/s (max. 50m/s)	Supply	18–36 V DC
Temp. range heated	-40 °C up to +58 °C	Shaft heating <5°C	18–33 V DC max. 0,4 A
Temp. range normal	-20 °C up to +58 °C	Current consumption	< 80 mA without heating
Shock	25 g, 6 ms	Immunity standard	EN61000-6-2
Vibration	3 g Sinus, 5–1000 Hz	Emission standard	EN61000-6-4

ABSOLUTELY ACCURATE WITHOUT SHADING

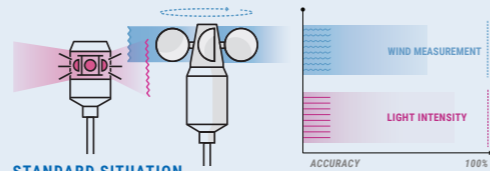

The obstruction light disables the airflow and the wind sensor obstructs the uniform radiation of the light.

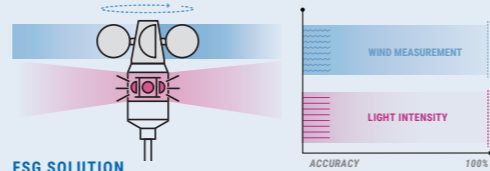

Reliable, accurate readings and unrestricted light intensity by combining two systems.

LUMINOUS BODY

- Horizontal radiation angle of 360°
- Optionally with automatic twilight switch
- Redundant light concept

PENDULUM

The vertical position of the wind sensor and the obstruction light takes place independent of the angle of the carrier object (e.g. crane boom) by means of a pendulum.

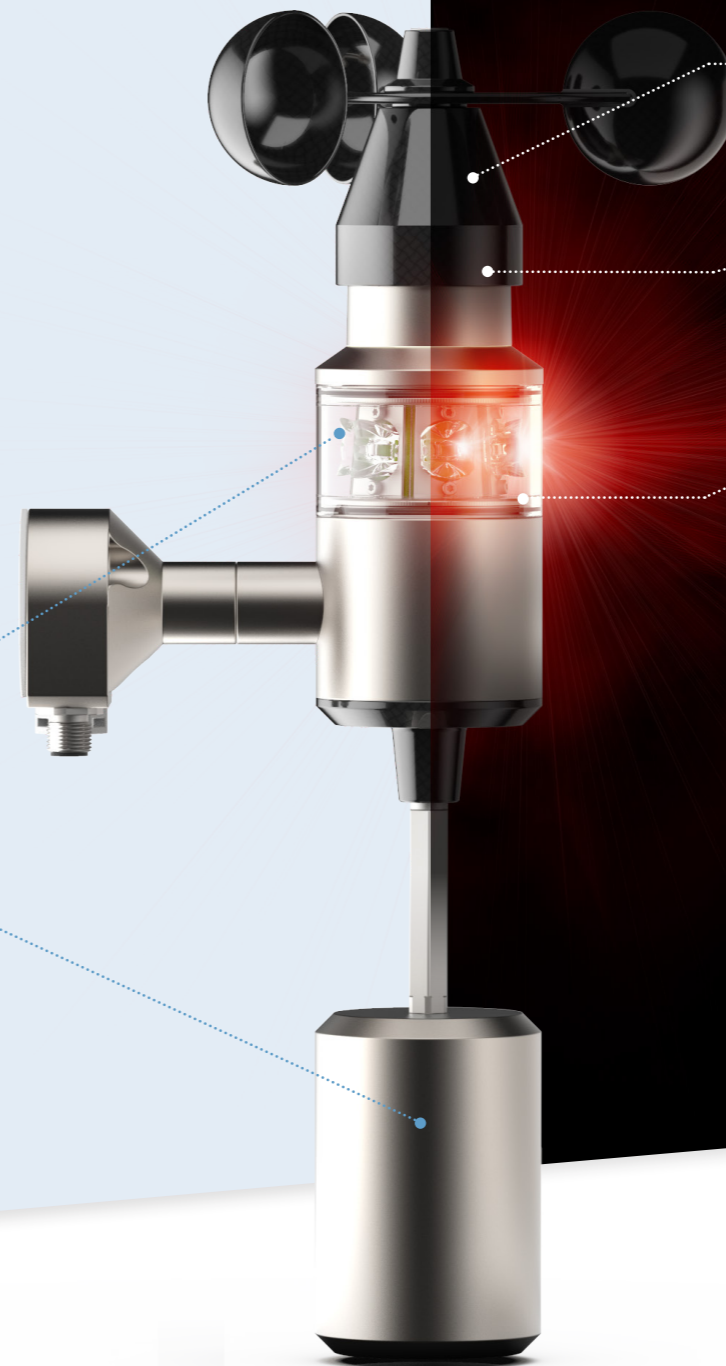
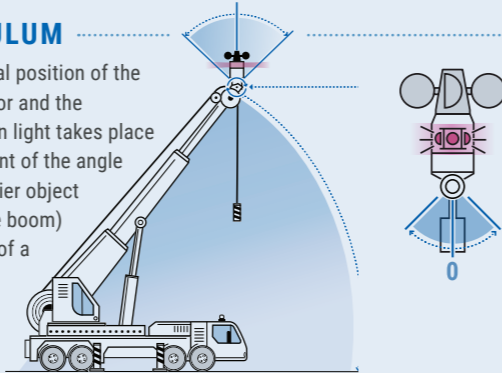

WIND SENSOR

The anemometer is made of aluminum, anodized and equipped with rigid cup star as standard. The electrical connection is freely selectable.

SHAFT HEATING

The electronically controlled heater switches on automatically at a temperature of +5 °C and ensures the operating range of both devices down to -40 °C.

FAIL-SAFE DUE TO REDUNDANT LED CONCEPT

The minimum luminous intensity of 10 cd is guaranteed at all times. Since all LED's only work with reduced power in normal operation, the power of functioning LED's can be increased to such an extent that the required luminous intensity is still guaranteed in case of LED failures.

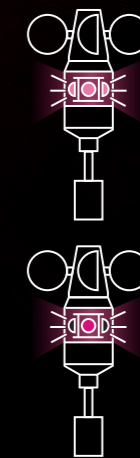

NORMAL OPERATION

all LED's work with reduced power

IN CASE OF MALFUNCTION

Power of each LED is adjusted to guarantee the minimum luminous intensity

● NORMAL OPERATION ● FAILURE ● INCREASED PERFORMANCE

TECHNICAL DATA OBSTRUCTION LIGHT

Illuminants	2 x LED-Array
Minimum luminous intensity	10 cd (red) 32 cd (red)
Power input	5,6 W without heating
Electronic	redundant
Lifetime (LM80 (17 k))	> 36.000 h (LED)
AVV	at 10 cd – yes ES – yes (extended specification)
ICAO	at 10 cd – Low-intensity, Typ A at 32 cd – Low-intensity, Typ B
WSV-Certificate	at 10 cd – yes at 32 cd – no

AVAILABLE SIGNAL OUTPUTS

Type designation	Signal output
AN-60-P-MH-2L	4–20 mA / 2-wire technology
AN-60-P-MH-3L	4–20 mA / 3-wire technology
AN-60-P-MH-SPA	0–10 V
AN-60-P-MH-CAN	CAN-Bus / CANopen
AN-60-P-MH-Pnet	Profinet

CE – conform

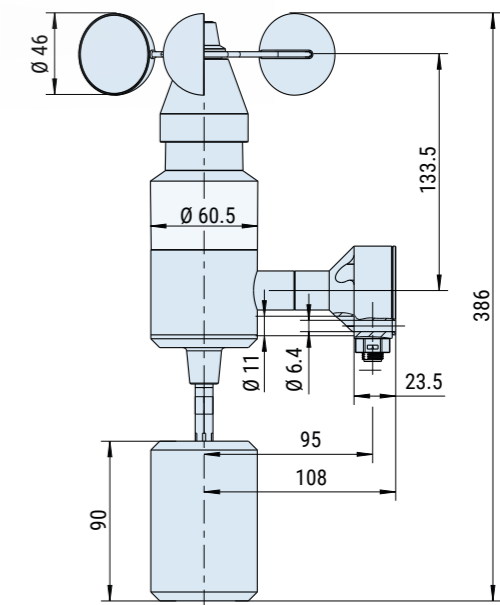



WE
MEASURE
CONTROL
REGULATE
IT

 **BERLIN (HQ)**

Fernsteuergeräte
Kurt Oelsch GmbH
Jahnstraße 68 + 70
12347 Berlin

fon +49 30 6291-1
fax +49 30 6291-277

info@fsg-sensors.de
www.fsg-sensors.de

